

HSC-18P

(ESC4001216) HSC-18P/115V 60Hz 1Ph/R-410A/미국/DUCT TYPE/판매용
 (ESC4001221) HSC-18P/115V 60Hz 1Ph/R-410A/미국/DUCT TYPE/렌탈용

[EXTERNAL PARTS]

(1/4)

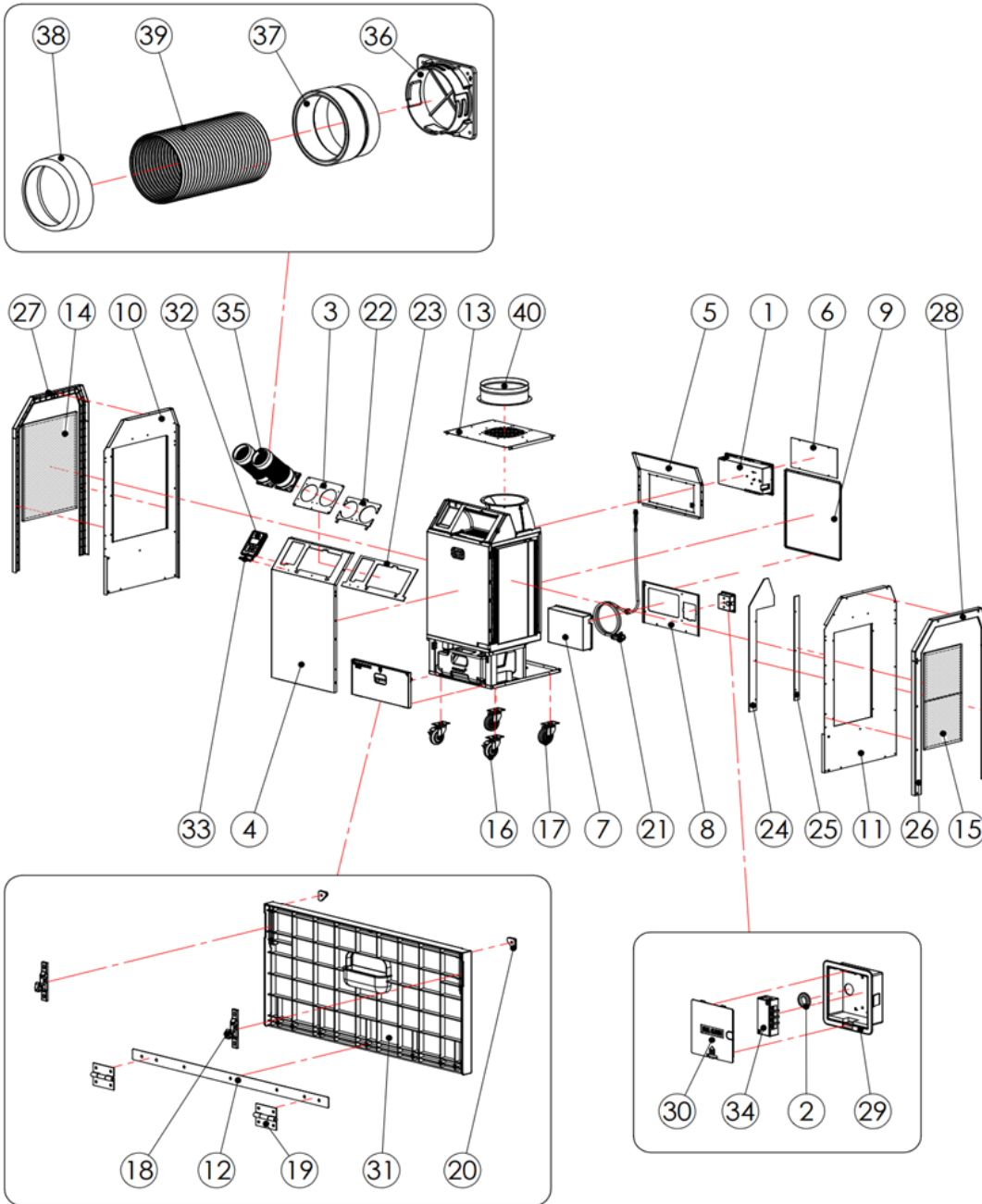

NO	PART	CODE NO	NO	PART	CODE NO	NO	PART	CODE NO	NO	PART	CODE NO
1	HSC-18P 115V 60Hz 1Ph	EPB1216	11	SIDE RH HSC-14P	A252611	21	LCDI 5-20 3.9m +SR 30382030	A670082	31	TANK DOOR HSC-14P 8D04	A900178
2	BUSHING RUBBER 20φ 막힘	991374	12	TANK DOOR SUPPORT HSC-14P	A252614	22	INSU-DUCT BASE PLATE HSC-14P	A750859	32	AIRREX 2023 FRONT조립 AHSC/HSC-14/18/24P	ESF8084530
3	DUCT BASE PLATE HSC-14P	A252588	13	TOP HSC-14P	A252615	23	INSU-FRONT HSC-14P	A750872	33	NAME PLATE AIRREX 다이아 커팅 2006	H250817
4	FRONT HSC-14P	A252590	14	COND 10T 4겹 HSC-14P	A300100	24	INSU-EVAP SIDE-1 HSC-14P	A750873	34	TERMINAL BLOCK DFT 20A 4P	W700012
5	POWER BOX PLATE HSC-14P	A252598	15	EVAP 10T 4겹 HSC-14P	A300101	25	INSU-EVAP SIDE-2 HSC-14P	A750874	35	DUCT KIT/2구/TW(21년) Ø125(5")x0.3m/LIGHT GRAY	GAC69044
6	POWER BOX COVER HSC-14P	A252600	16	TP5040-01-PLYTLB B/K (LOCKABLE)	A500026	26	BUMPER-1 HSC-14P GRAY BUMPER-1 HSC-14P GREEN	A900157 A900183	36	DUCT BASE / Ø125(5") LIGHT GRAY 8D04	A900181
7	POWER CORD HOLDER HSC-14P	A252602	17	TP5040-01-PLY NO LOCKER GRAY	A500027	27	BUMPER-2 LF HSC-14P GRAY BUMPER-2 LF HSC-14P GREEN	A900158 A900184	37	2021년형 DUCT LOWER LIGHT GRAY 8D04	A900182
8	REAR LOWER HSC-14P	A252605	18	캐취 C3-303	A560505	28	BUMPER-2 RH HSC-14P GRAY BUMPER-2 RH HSC-14P GREEN	A900159 A900185	38	DUCT COVER LIGHT GRAY 8D04	A900193
9	REAR UPPER HSC-14P	A252607	19	경첩 BYHS1550-40	A560513	29	FIRE ALARM BOX HSC-14P 8D04	A900175	39	DUCT Ø125 0.3M PP	A970125
10	SIDE LF HSC-14P	A252609	20	DOOR PROTECT RUBBER	A560524	30	FIRE ALARM COVER HSC-14P 8D04	A900176	40	DUCT FLANGE Ø300	A252044

HSC-18P

(ESC4001216) HSC-18P/115V 60Hz 1Ph/R-410A/미국/DUCT TYPE/판매용
 (ESC4001221) HSC-18P/115V 60Hz 1Ph/R-410A/미국/DUCT TYPE/렌탈용

[INTERNAL PARTS]

(2/4)

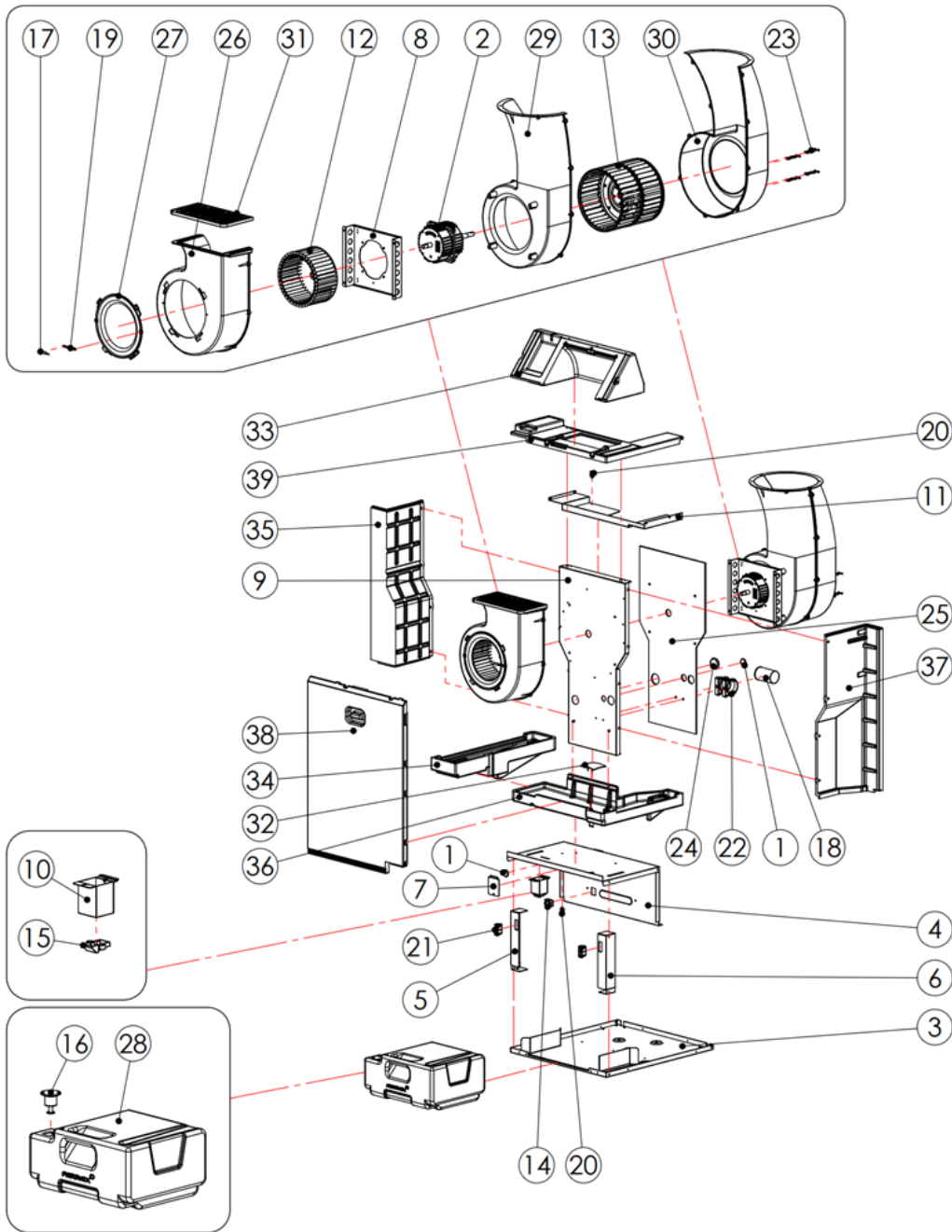

NO	PART	CODE NO	NO	PART	CODE NO	NO	PART	CODE NO	NO	PART	CODE NO
1	BUSHING RUBBER 20φ 막힘	991374	11	SIDE SUPPORT HSC-14P	A252613	21	캐뮼 C3-303	A560505	31	FAN TOP HSC-14P 8D04	A900174
2	BLDC DL-12850H5BA 220V 50/60Hz	A200121	12	Impeller CF AL CCW Ø200 X 100mm X Ø14 X 40P	A400104	22	PIPE CLIP 50mm GRAY	A560508	32	EVAP DRAIN CAP HSC-14P	A900198
3	BASE HSC-14P	A252587	13	Impeller CF AL CW Ø227 X 210mm X Ø14	A400105	23	TWIST LOCK STANDOFF DASTL-12NB	A560514	33	EPP-AIR GUARD HSC-14P	A930009
4	MIDDLE HSC-14P	A252592	14	DOOR SWITCH HC-050K4	A430081	24	BUSHING RUBBER 35φ 막힘	A560516	34	EPP-COND DRAIN HSC-14P	A930010
5	MIDDLE SUPPORT-LF HSC-14P	A252593	15	PROXIMITY SENSOR 1,300mm	A430089	25	INSU-PARTITION HSC-14P	A750860	35	EPP-COND GUARD HSC-14P	A930011
6	MIDDLE SUPPORT-RH HSC-14P	A252594	16	FLOATING ACCESSORIES	A430090	26	DUCT COVER 난연 ABS	A900141	36	EPP-EVAP DRAIN HSC-14P	A930012
7	PUMP CONNECTOR COVER HSC-14P	A252595	17	THERMISTOR TA502HW-1300(검정색)	A430091	27	BELL MOUTH 난연 ABS	A900143	37	EPP-EVAP GUARD HSC-14P	A930013
8	MOTOR BKT HSC-14P	A252596	18	250V 60uF RNV-25H6005 UL	A460029	28	CONDENSATE TANK HSC-14P	A900156	38	EPP-FRONT GUARD HSC-14P	A930014
9	PARTITION HSC-14P	A252597	19	RETAINER COIL DALG-2	A530007	29	DUCT BACK-01 HSC-14P	A900172	39	EPP-TOP GUARD HSC-14P	A930015
10	PROXIMITY SENSOR BKT HSC-14P	A252604	20	WIRE SADDLE DAWS-2NL	A560502	30	DUCT BACK-02 HSC-14P	A900173	40		

HSC-18P

(ESC4001216) HSC-18P/115V 60Hz 1Ph/R-410A/미국/DUCT TYPE/판매용
 (ESC4001221) HSC-18P/115V 60Hz 1Ph/R-410A/미국/DUCT TYPE/렌탈용

[ELECTRICAL PARTS]

(3/4)

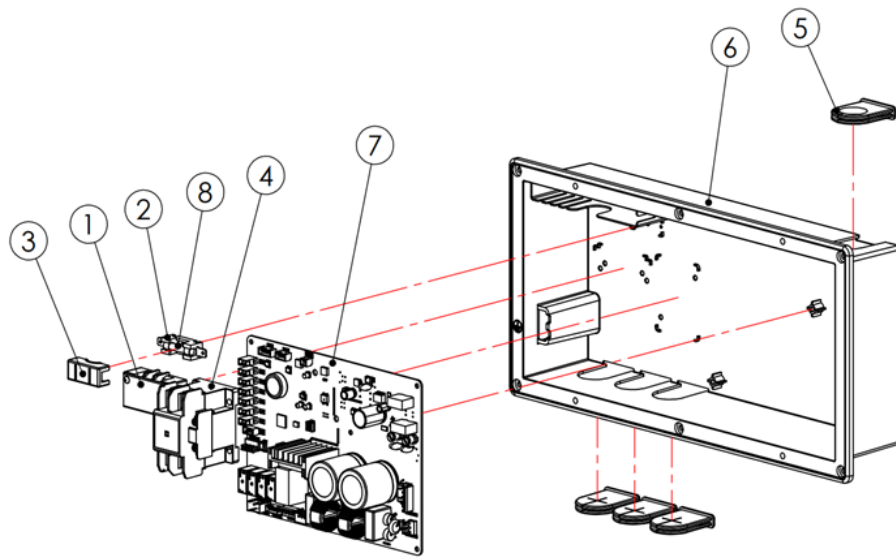

NO	PART	CODE NO	NO	PART	CODE NO	NO	PART	CODE NO	NO	PART	CODE NO
1	TERMINAL BLOCK DFT 30A 3P	A530013	11			21			31		
2	FUSE BLOCK FB66A 250V 15A	A530061	12			22			32		
3	FUSE BLOCK COVER FB66A	A530062	13			23			33		
4	M/C GMC-20P2 AC110V 60Hz	A530162	14			24			34		
5	BUSHING RUBBER 30Φ U-TYPE	A560506	15			25			35		
6	POWER BOX HSC-14P 8D04	A900177	16			26			36		
7	AIRREX 2023 HSC-14P/18P AC115V MAIN 조립	ESM8084531	17			27			37		
8	FUSE 312 010 MXP 250V 10A	H560044	18			28			38		
9			19			29			39		
10			20			30			40		

HSC-18P

(ESC4001216) HSC-18P/115V 60Hz 1Ph/R-410A/미국/DUCT TYPE/판매용
 (ESC4001221) HSC-18P/115V 60Hz 1Ph/R-410A/미국/DUCT TYPE/렌탈용

[REFRIGERTION CYCLE PARTS]

(4/4)

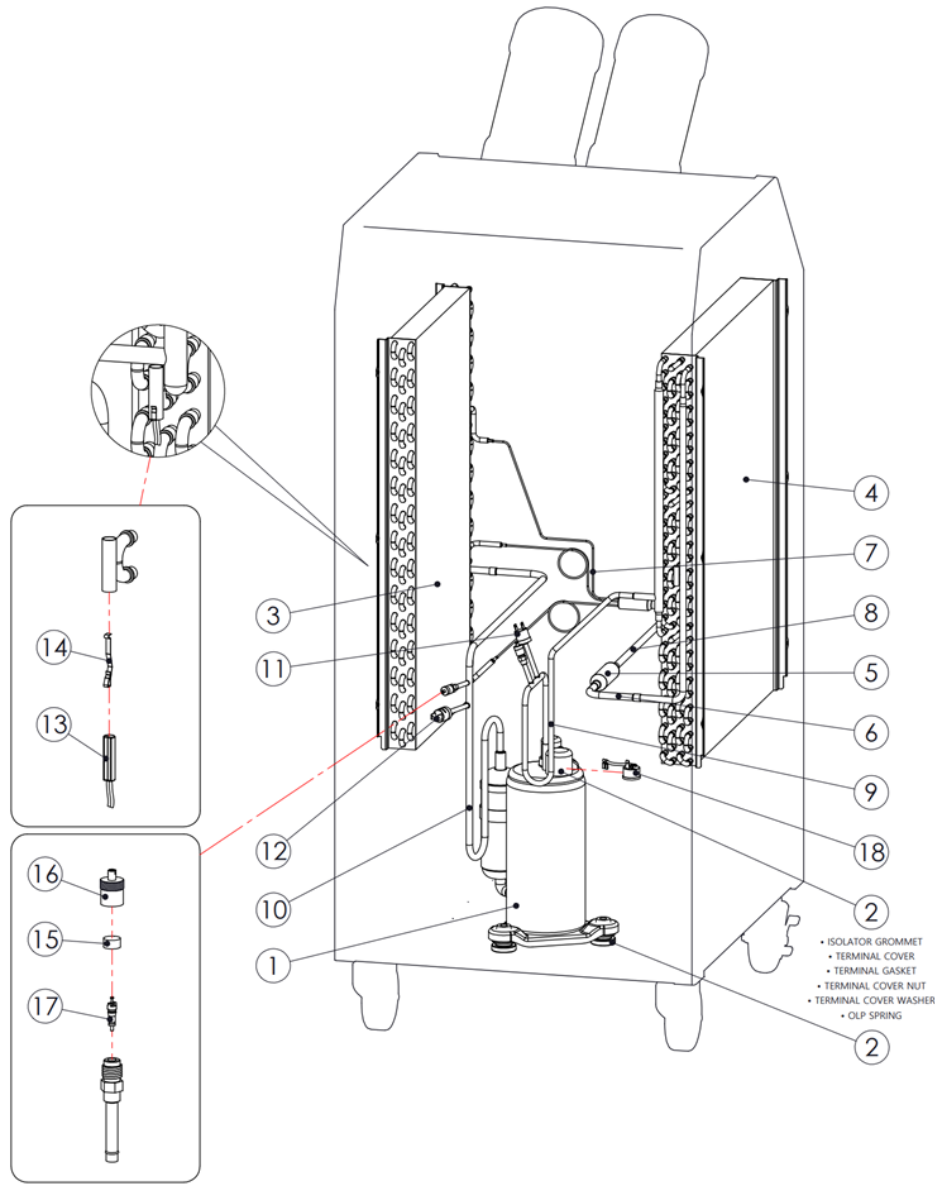

NO	PART	CODE NO	NO	PART	CODE NO	NO	PART	CODE NO	NO	PART	CODE NO
1	RECHI 44A361AK-5EKD-01 115V 60Hz R-410A	A100144	11	PRESSURE S/W H20P5 (4.5/3.2MPA)	A430009	21			31		
2	COMPRESSOR ACCESSORY KIT	A100145	12	PRESSURE S/W H20P5 (0.2/0.3MPA)	A430022	22			32		
3	EVAP Ø7-3R-305-310EL HSC-18P	A150107	13	THERMISTOR TA502HW-1100C(노란색)	A430092	23			33		
4	COND Ø7-4R-305-450EL HSC-18/24P	A150111	14	CLIP THERMISTOR 4930A20053A	A560009	24			34		
5	DRIER 20G	A350001	15	CHECK VALVE CAP 고무링	A560010	25			35		
6	COND OUT HSC-14P	A350602	16	CHECK VALVE CAP	A560011	26			36		
7	CAPILLARY ø1.0X400mmX3ea HSC-14/18P	A350605	17	CHECK CHARGE 무시(HSC공통)	A560012	27			37		
8	CAPILLARY IN HSC-14/18/24P	A350606	18	OLP MRA12170-12038	A560507	28			38		
9	DISCHARGE HSC-18P	A350607	19			29			39		
10	SUCTION HSC-18P	A350608	20			30			40		